

Product Description

The DNT-T103 is an intelligent room thermostat with a custom 3-value, 96 segment LCD display. The DNT-T103 can communicate on a BACnet MS/TP network or on Delta’s proprietary LINKnet network.

The DNT-T103 can display a wide-range of digital or analog values, including setpoints, temperature, air flow, heating and cooling status, fan speed, valve and damper position, and more.

When connected on a BACnet MS/TP network the DNT-T103 functions as an independent BACnet thermostat. When connected to a controller, on a LINKnet network, it provides a programmable remote sensor and expanded I/O capabilities. This version’s firmware can be flash loaded over the network, and has a termination resistor that is jumper selectable.



Contents

MODEL NUMBERS	2
PACKAGE CONTENTS	2
OTHER RELEVANT DOCUMENTS	2
PRODUCT SPECIFICATIONS	2
PCB BOARD LAYOUT	4
JUMPERS	5
MOUNTING	6
WIRING DIAGRAM	6
POWER	7
NETWORK CABLING & REQUIREMENTS	7
NETWORK TOPOLOGY	9
CAUTIONS & WARNINGS	9
COMPLIANCE DECLARATIONS	10

Model Numbers

Features	DNT-T103	DNT-H103B	DNT-T103-UL864
Internal Thermistor Input	✓	✓	✓
Internal Humidity Input		✓	
Additional I/O (1 IP and 3 OP)	✓	✓	✓
Backlighting	Option B	✓	✓
External Input Terminator	Option X	✓	✓
Button Icons	INT	INT	INT

An appended button icon code must be included to specify the desired icons embossed on the buttons as follows:

[*default*] Bottom 2 buttons are ▼ and ▲ (Setpoint Adjust), top 2 are OFF and ON

INT Bottom 2 buttons are ▼ and ▲ (Setpoint Adjust), top 2 are O and I – *International*

You need not specify button icons if you want the default, but must specify INT if you want the international button icons (i.e., DNT-T103-INT).

Package Contents

- Delta Network Thermostat: BACstat II Product, **DNT-T103 (Rev 4.1)**
 - **DNT-T103 (Rev 4.1)** Installation Guide
-

Other Relevant Documents

- Delta Controls Wiring and Installation Guidelines
 - BACstat II Application Guide (for Configuration & Programming)
 - ORCAview Operator Guide
 - ORCAview Technical Reference Manual
 - BACstat II, DAC and DCU Release Notes
-

Product Specifications

Power Requirements

- 24VAC, 50/60 Hz (Class 2)
- 41 VA maximum (with internally powered triacs at full load)
(3 VA with triacs externally powered)

Ambient Ratings

- 0°C to 40°C (32°F to 104°F)
- 10 to 90% RH (non-condensing)

Communication Port

LINKnet Connection

- Communications Speed @ 76,800 bps
- Up to 12 Devices per segment (depending on the controller), only two of which can be DNT or DFM devices

BACnet MS/TP Connection

- Communications Speed @ 9,600 or 19,200 or 38,400 or 76,800 bps (the default)
- Maximum of 99 nodes per MS/TP segment (50 without a repeater)
- Firmware can be flash loaded over the network

Temperature Sensor (IP1)

- Thermistor Input – 10,000 ohm @ 77 °F (25 °C)
- Accuracy of +/- 0.36 °F from 32 - 158 °F (+/- 0.2 °C from 0 - 70 °C)
- Display Resolution of 0.1 °F or °C
- Stability of 0.24 °F over 5 years (0.13 °C)
- Optional Termination point for an External Thermistor on Input 1
 - Jumper Selectable for Internal or External Thermistor
 - Use a standard 10 K Ω Thermistor (10,000 ohm @ 77 °F / 25 °C)

Humidity Sensor (DNT-H103B Model Only)

- Accuracy of +/-2% RH from 0-100% RH (25°C, V_{SUPPLY} = 2.6Vdc)
- Display Resolution of 0.1 %
- Stability of +/- 1% RH typical @ 50% RH over 5 years

*Note: Extended exposure to >90% RH causes a reversible shift of 3% RH

Input (Additional)

- 1 Universal Input (10 bit), jumper configurable for the following input types:
 - 0-5 VDC
 - 0-10 VDC
 - 10 K Ω Thermistor
 - Dry Contact (using 10 K Ω Thermistor jumper setting)

Outputs

- 3 Binary Triac Outputs
 - Switching 24 VAC @ 0.5 Amp maximum per output
 - Leakage Current per Triac is 100 μ A
 - Jumper Selection for Internal or External Power
 - Software Configurable for Binary, PWM, Time Proportioned, or Tri-State Actuators

Technology

- 32-bit Processor c/w internal A/D, Flash, and RAM
- 3-value LCD c/w icons (96 total segments) and optional backlighting
- 4 stylized momentary push buttons with tactile feedback

Device Addressing

LINKnet Connection

- Set via Keypad Configuration Setup
- Address Range: 1 to 12

BACnet MS/TP Connection

- Set via Keypad Configuration Setup, or Software Setup
- Keypad MAC Address Range: 1 to 99 per network segment
- Software Address Range: As per the BACnet standard
- Supports DNA – Delta’s intuitive addressing scheme

Size

- 5” x 3.25”x 1” (12.7 cm x 8.3 cm x 2.5 cm)

Weight

- 0.3 lb. (134 g)

PCB Board Layout

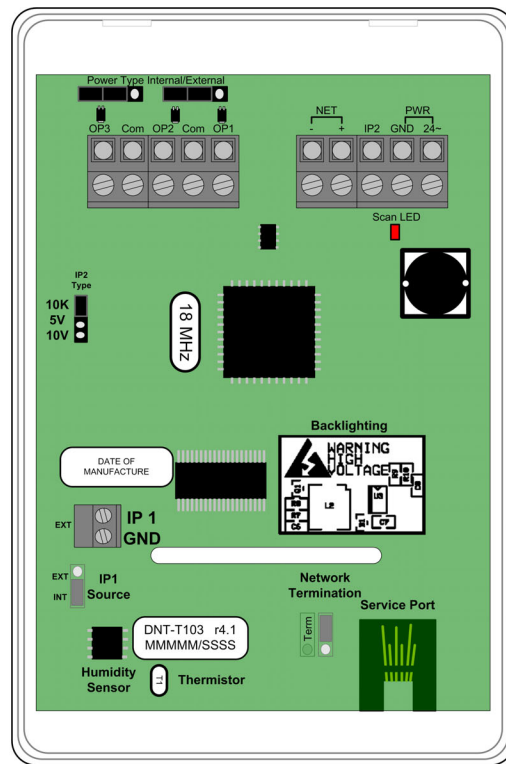
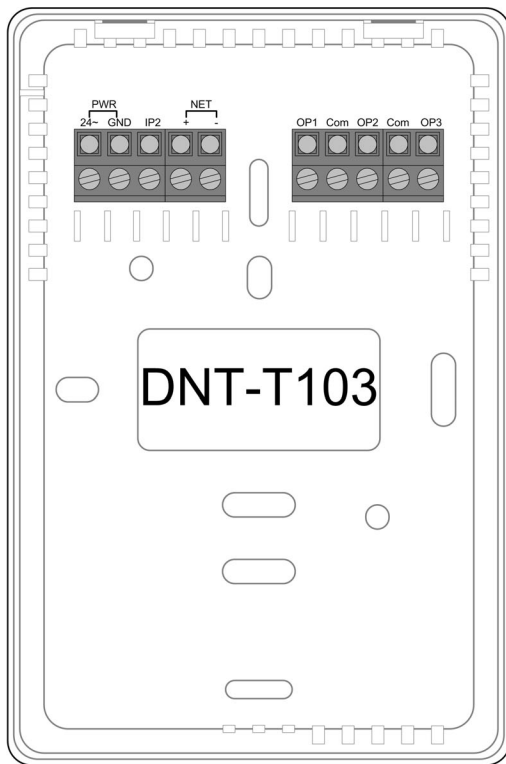

Jumpers

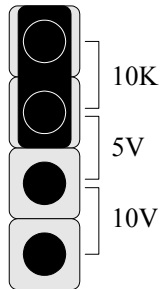

INPUT SIGNAL TYPE

The input type is selected by placing the jumper in the correct location on the Input Type Selector Block. The diagram to the left shows the factory default selection of 10 K Ω .

- 10K ▪ For 10 K Ω Thermistor temperature sensors, as well as Binary or Dry Contact inputs.
- 5V ▪ For sensors and other field devices that use a 5 VDC signal.
- 10V ▪ For sensors and other field devices that use a 10 VDC signal.

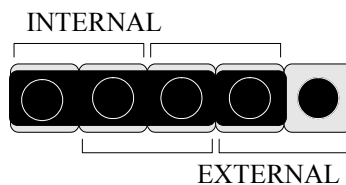

BINARY OUTPUT POWER SOURCE

The binary triac outputs can be selected to use either an internal or external power source by placing the two jumpers in the correct locations. The diagram to the left shows the factory default selection of Internal Power Source.

- Internal ▪ 24 VAC Power is provided internally from within the board right to the output terminals. No external transformer is required. The associated triac outputs are “hot” contacts. Note that the power supply should be sized appropriately to handle the additional loading.
- External ▪ Power needs to be provided externally to the board from a nearby transformer appropriately connected to the output wiring. The associated triac outputs are *not* “hot” contacts, except by means of the external transformer.

NOTE: Triacs are solid-state components that are only appropriate for switching 24 VAC. They cannot be used to switch DC voltage. They also have a small leakage current and may not be appropriate for certain “dry contact” applications.

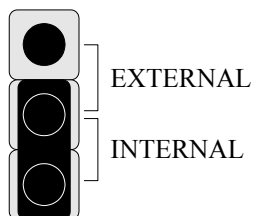

INPUT CONNECTION SELECTOR – DNT-T103X MODELS ONLY

This jumper is used to select whether the internal Thermistor sensor or a remotely located Thermistor is connected to IP1. The diagram to the left shows the factory default selection of the Internal 10 K Ω Thermistor.

- External ▪ For connecting a remotely located 10 K Ω Thermistor temperature sensor to IP1, which is wired to the connection terminals provided.
- Internal ▪ For connecting the internal 10 K Ω Thermistor temperature sensor to IP1.

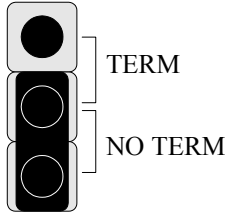

NETWORK TERMINATION RESISTOR

This jumper is used to select the termination resistor at each end of each MS/TP network segment. The diagram to the left shows the factory default selection of No Term.

Mounting

The BACstat II backplate is designed for mounting directly on standard North American, European or Australian electrical boxes.

Wiring Diagram

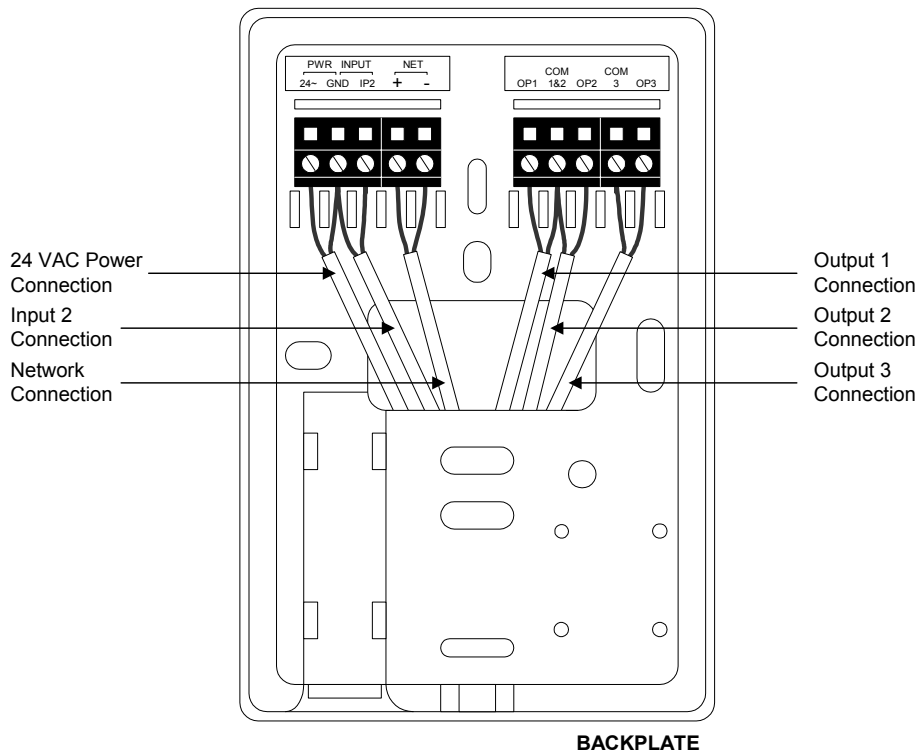

Warning:

The network shield and any other bare wires should be bent back and taped to ensure that they do not come into contact with the board electronics and cause a short. Otherwise you run the risk of damaging the BACstat.

Notes:

1. Ensure you use the recommended balanced cable for the network and follow and follow the documented procedures within *Delta Controls Wiring and Installation Guidelines* for MS/TP or LINKnet networks.
2. Do *not* use 4-wire multi-conductor cable for network and power, as it will not meet the balanced cable requirements for the MS/TP or LINKnet networks. Use two separate cables: one for the network and the other for power.
3. Do not terminate the network shield on the BACstats, but ensure shield conductivity is maintained along the network from end-to-end with wire nuts as necessary.
4. If the same power source is used for more than one device, ensure that the transformer is properly sized for the rated VA and that the same polarity is observed from device to device.

Power

The DNT-T103 requires a 24V AC Class 2 power supply. The VA requirements vary depending on the output configuration as follows:

- 41 VA maximum (with internally powered triacs at full load)
- 3 VA (with triacs externally powered)

More than one device – not including DCUs or V2 products – may be connected to the same transformer, if the transformer is properly sized (including line losses), and the polarity is observed between controllers (in regards to 24~ and GND). The transformer must **ONLY** be used to provide power to other MS/TP or LINKnet devices and field devices powered through its outputs. Auxiliary field devices (i.e., 4-20 mA devices) that don't use ½ wave rectification must be powered separately.

For more information refer to the *Delta Controls Wiring and Installation Guidelines*.

Network & Cabling Requirements

Adhere to the following network and cabling requirements to ensure network stability and reliable communications, particularly at high speeds on the RS-485 MS/TP or LINKnet networks.

Item	Description
Cabling	For MS/TP and LINKnet networks it is recommended that you use network cabling that matches the following specifications: <ul style="list-style-type: none"> • Balanced 100 to 120 Ω nominal impedance Twisted Shielded Pair (TSP) Cable • Nominal capacitance of 16 PF/FT or lower • Nominal velocity of propagation of 66% or higher
Topology	For MS/TP and LINKnet networks, ensure the cable is installed as a <i>daisy-chain</i> from one device to the next.
Max. Nodes	<ul style="list-style-type: none"> • <u>MS/TP</u>: The maximum number of devices per MS/TP network without any repeaters is 50. • <u>LINKnet</u>: Up to a maximum of 12 Devices (depending on the controller), only two of which can be DNT or DFM devices. (Refer to the Appendix called <i>Working with MS/TP and LINKnet</i> in the <i>Technical Reference Manual</i> for more information.)
Termination	<ul style="list-style-type: none"> • <u>MS/TP</u>: A termination resistor must be jumper selected at each end of each MS/TP network

Boards	segment. Ensure you do not overlook this in laying out your network architecture. <ul style="list-style-type: none">• <u>LINKnet</u>: Jumper select a termination resistor on each end of the network when there are more than 2 nodes. Termination resistors do not need to be installed for one or two nodes.
Repeater	<ul style="list-style-type: none">• <u>MS/TP</u>: A repeater (RPT-768) is not necessary unless more than 50 nodes will be installed on a network <i>or</i> you need to extend the network beyond 4000 ft (1220 m).• <u>LINKnet</u>: Repeaters should not be necessary. Ensure the maximum distance is no more than 1000 ft (300 m).

For more information refer to the *Delta Controls Wiring and Installation Guidelines*.

Network Topology

1. BACstats Configured as MS/TP Subnet Devices

With V3.21 firmware or higher, one possible MS/TP network architecture has the MS/TP devices configured as Subnet devices, which allows BACstats to reside on the MS/TP network with other Subnet devices. Note that V3.21 requires a DCU, while V3.22 or higher may use any System Controller instead.

2. BACstats Configured as LINKnet Devices

The BACstat may reside on LINKnet instead of MS/TP. However, this requires a controller that supports a LINKnet network for I/O expansion. The maximum LINKnet devices with or without I/O depends on the controller. All built-in applications must be disabled, but the I/O may be muxed (with V3.22 firmware).

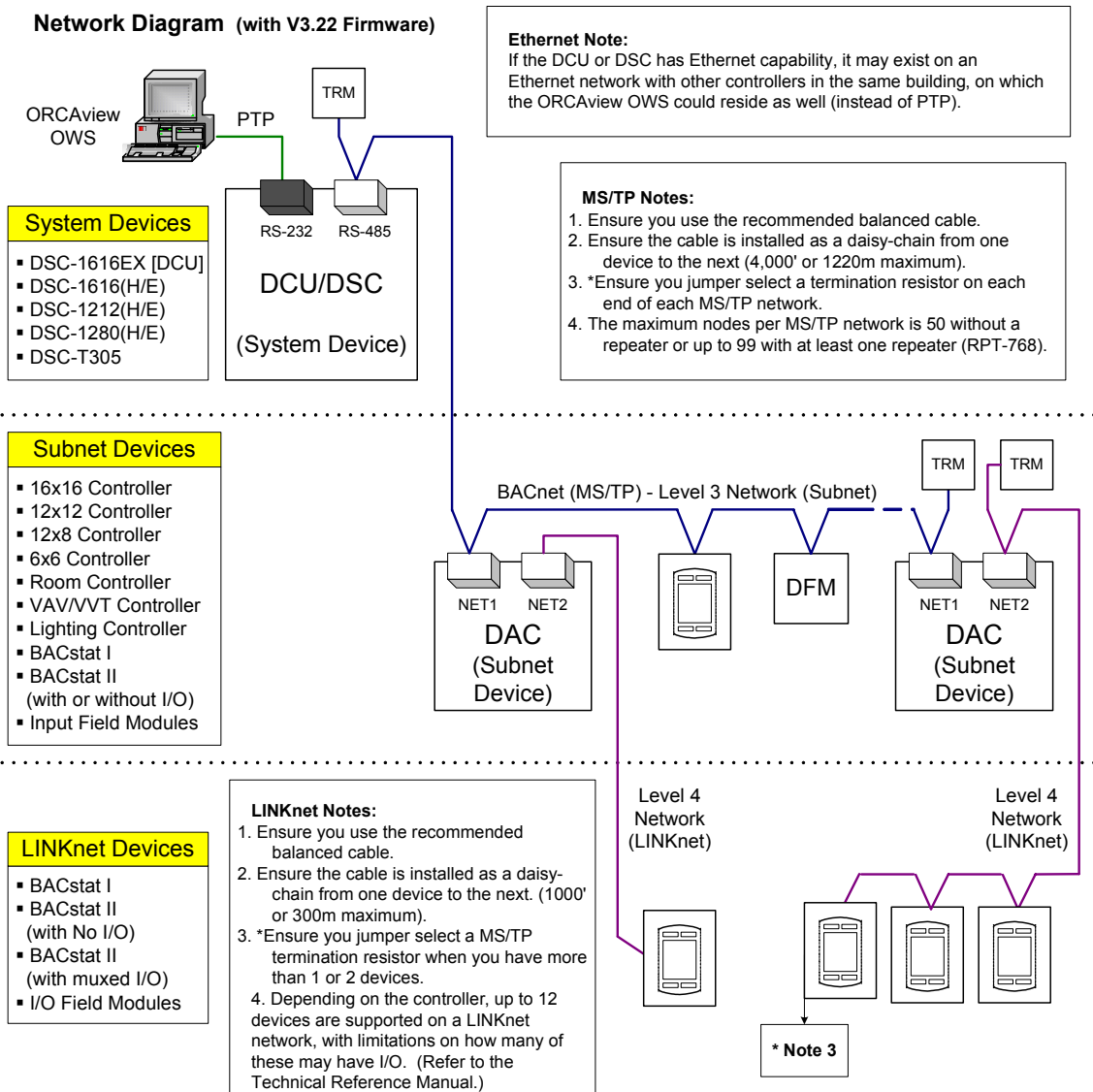



Cautions and Warnings

The DNT-T103 BACstat II is an electrostatically sensitive device. An ESD protection (ground strap) should be unnecessary if sufficient care is taken in handling because the electronics are contained within the product housing.

UL 864 Specific Considerations

- Use the transformer by Core Components Inc., Model No. 120-024-100-2TF-CB to power the device.
- Use only UL Listed Class 2 Power Supplies for auxiliary field devices.

Compliance Declarations

FCC Compliance Information

This equipment has been tested and found to comply with the limits for a Class B digital device, pursuant to Part 15 of the FCC Rules. These limits are designed to provide reasonable protection against harmful interference in a residential installation. This equipment generates, uses, and can radiate radio frequency energy and, if not installed and used in accordance with the instructions, may cause harmful interference to radio communications. However, there is no guarantee that interference will not occur in a particular installation. If this equipment does cause harmful interference to radio or television reception, which can be determined by turning the equipment off and on, the user is encouraged to try to correct the interference by one or more of the following measures:

- Reorient or relocate the receiving antenna.
- Increase the separation between the equipment and receiver.
- Connect the equipment into an outlet on a circuit different from that to which the receiver is connected.
- Consult the dealer or an experienced radio/TV technician for help.

Industry Canada Compliance Statement

ICES-003 This Class B digital apparatus meets all requirements of the Canadian Interference-Causing Equipment Regulations.

Cet appareil numérique de la Classe B Respecte toutes les exigences du Règlement sur le matériel brouiller du Canada.

UL Compliance Information



This product conforms to the following UL requirements:

- UL916: Energy Management Equipment
- UL 864: Control Units and Accessories for Fire Alarm Systems
- CAUTION – Risk of Electric Shock – More than one disconnect switch may be required to de-energize the equipment before servicing
- All terminals are acceptable for Class 2 circuit connection only
- CAUTION – Input Class 2 Power Supplies are interconnected. To Reduce the Risk of Fire or Electric Shock, Use only Class 2 sources Suitable for Interconnection
- Use Copper Conductor Only
- Select an external power supply that is certified for safety for the correct destination country and that has an output rating, which is considered an NEC Class 2 or Limited Power Source with the rating not to exceed 30 V rms, 42.4 V peak, 100 VA.
- Apply minimum 6.0 lb-in torque for tightening field wires into the terminal blocks.

CE - DECLARATION OF CONFORMITY

according to ISO/IEC Guide 22 and EN 45014

Manufacturer's Name: Delta Controls
Manufacturer's Address: 17850 56th Avenue
Surrey, British Columbia
Canada
V3S 1C7

declares that the product (s):

Product Name: BACstat II - Binary
Model Numbers: DNT-T103
Product Options: All

conforms to the following Product Specifications:

EMC:	EN 55022:1994	Radiated and Conducted Emissions	Class B
	EN 50082-1:1997	Generic Immunity Standard	
	EN 61000-4-2:1995 + A1:1999	ESD Immunity	Level A
	EN 61000-4-3:1996	RF Electromagnetic Field Immunity	Level A
	ENV 50204:1995	RF Electromagnetic Field Immunity (Keyed)	Level A
	EN 61000-4-4:1995	EFT/Burst Immunity	Level B
	EN 61000-4-5:1995	Surge Immunity	Level B
	EN 61000-4-6:1996	Conducted RF Disturbances Immunity	Level A
	EN 61000-4-11:1994	Voltage Dips / Interruptions	Level B/C

Supplementary Information:

The product(s) herewith comply with the requirements of the EMC Directive 89/336/EEC. The product(s) were tested in a typical configuration.

Lee Dickson
Quality Assurance Manager

